

EV-8626

GLORY

NOTE COUNTER.

Engineered for accuracy and durability.



THE EV8626 EXEMPLIFIES PERFORMANCE AND VALUE. ITS EASE OF USE AND ACCURACY MEANS YOU CAN COUNT YOUR NOTES EFFICIENTLY, SAVING YOU TIME AND MONEY.

The EV-Series is a premium family of currency counters designed for efficiency, accuracy, and reliability for use in your most demanding cash counting applications. The EV-8626 is designed to deliver premium performance over the long haul. It offers superior price/performance along with a low cost of ownership.

The EV-8626 is offered in three variants all of which operate at speeds up to 1,500 notes per minute. Choose the standard unit or one of two variants with counterfeit detection capability in cases where there is risk of loss from fraudulent notes.

enabling you to process currency in all conditions reliably and quickly without damaging the notes. The EV-Series features an innovative 'gull wing' in-feed design, which means there are far fewer interruptions in processing due to feed errors that disrupt throughput on other counters.

Mechanical Double Detection™, which is also a unique Glory feature, provides unsurpassed counting accuracy. It is unaffected by soiled or stained notes and counting is decisive. A low stop rate mean less re-feeding of notes and reduced operator frustration.



MDD™
mechanical double detection

UF™
ultra feed

All EV-Series note counters offer Ultrafeed™ technology. Ultra Feed provides superior feeding of banknotes,

Advantage: Glory

Ease of use and simplicity

The keypad offers full travel keys and convenient left or right hand access. The backlit display is easy to read, and the operation itself is highly intuitive. Notes are neatly stacked far forward in the output stacker for easy access and removal, and the aesthetics of the EV-Series' design suits any modern, professional environment.

Superior feeding of banknotes

Ultrafeed™ technology enables superior feeding of banknotes in all conditions with fewer stops due to feed errors.

Mechanical Double Detection™

reduces false stops common with other note counters and provides unsurpassed counting accuracy.

Counterfeit detection capability

Choose a model with dual magnetic counterfeit detection aid or the top-of-the-line variant with both dual magnetic and ultraviolet counterfeit detection aid to reduce risk of loss from fraudulent banknotes.

EV-8626 TECHNICAL INFORMATION

Speed	800 - 1,500 notes per minute
Feed technology	UltraFeed™
Count accuracy technology	Mechanical Doubles Detection™ (MDD)
Capacity	Feed hopper: 500 notes Output stacker: 200 notes
Keypad	Numeric keypad with tactile keys
Dimensions (H x W x D)	10.43" x 11.81" x 10.35"
Weight	16.5 lbs (7.5 kg)
Power supply	98-264V AC, 50/60 Hz
List of variants	EV8626 Std EV8626 with Dual Magnetic Counterfeit Detection Aid EV8626 with Dual Magnetic and Ultraviolet Counterfeit Detection Aid

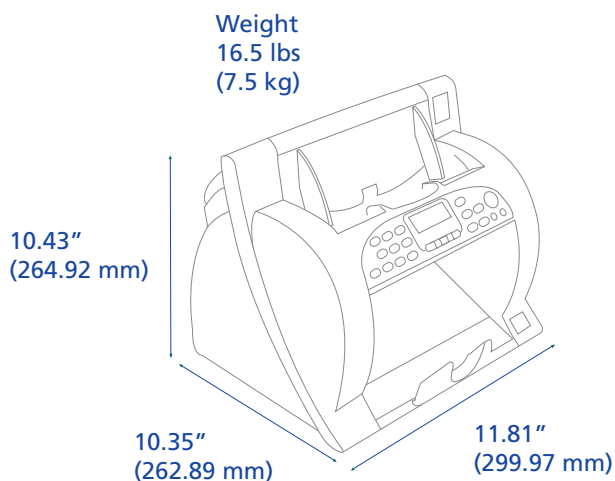

Specifications and design subject to change without notice. Please carefully read the instruction manual to ensure correct usage.



Glory Global Solutions

3333 Warrenville Road, Suite 310 Lisle, IL 60532
Tel: +1 (630) 577-1015
Fax: +1 (630) 577-1270
www.gloryglobalsolutions.com

Glory Global Solutions is part of GLORY LTD.

This document is for general guidance only. As the Company's products and services are continually being developed it is important for customers to check that the information contained herein includes the latest particulars. Although every precaution has been taken in preparation of this document, the Company and the publisher accept no responsibility for errors or omissions. The Company and the publisher accept no liability for loss or damages resulting from the use of the information contained herein. This document is not part of a contract or licence save insofar as may be expressly agreed. All capabilities and capacity and throughput figures are subject to note/coin size, note/coin quality and process used. GLORY is a registered trademark of GLORY LTD. in Japan, the United States of America, and EU. All trademarks are owned by the GLORY Limited Group of companies. © Glory Global Solutions (International) Limited 2013.